

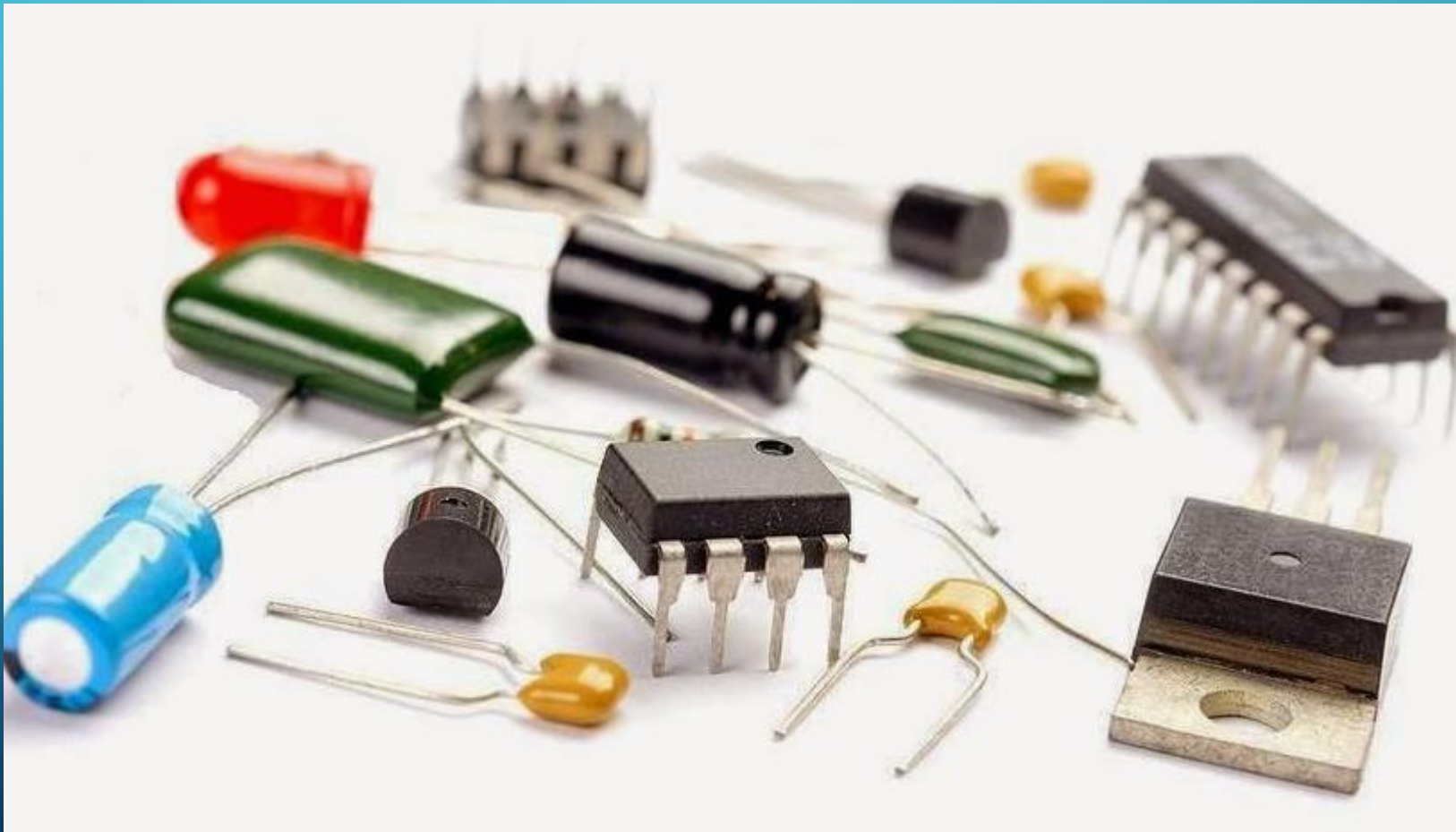

# 03. ELECTRONIC COMPONENTS

M2U1P3

# WHAT ARE ELECTRONIC COMPONENTS?



# ELECTRONIC COMPONENTS

- Electronic components are basic elements that are used to design electrical and electronic circuits
- They have a minimum of two terminals which are used to connect to the circuit

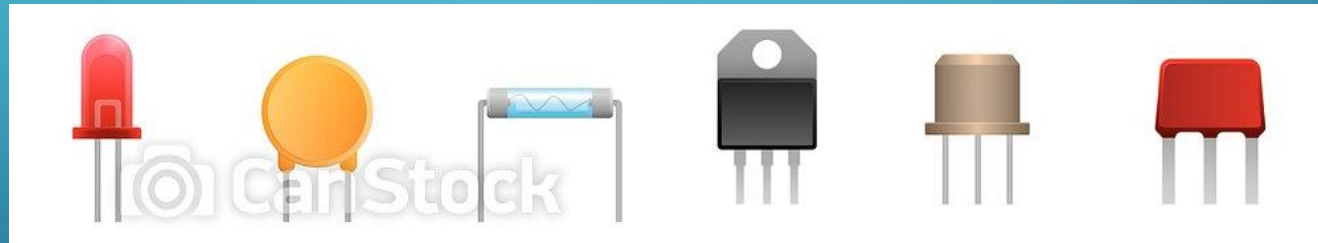

- The classification of electronic components can be done based on applications like active, passive, and electromechanical

# ACTIVE COMPONENTS

- They are used to amplify electrical signals to generate electric power
- An active component executes its functions because it is power-driven through an electricity source
- These components have 3 or more terminals



# PASSIVE COMPONENTS

- A passive component is an electronic component which can only receive energy, which it can either dissipate, absorb or store it in an electric field or a magnetic field
- Passive components cannot amplify, oscillate, or generate an electrical signal
- Passive components are: resistors, inductors, capacitors, transformers





# EXAMPLE: FLASHLIGHT

- A flashlight can be seen as a simple electrical circuit. It has 3 components,
  - Source
  - Switch
  - Lightbulb

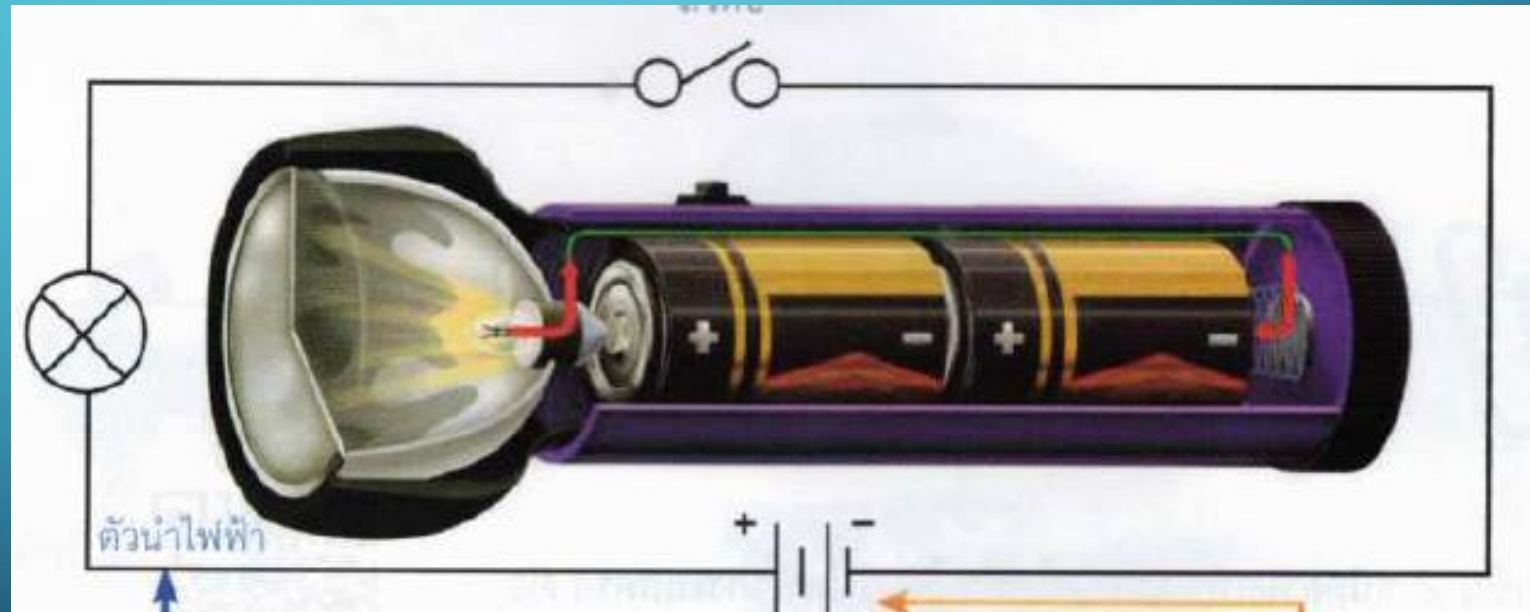

# EXAMPLE: FLASHLIGHT COMPONENTS

What is this?

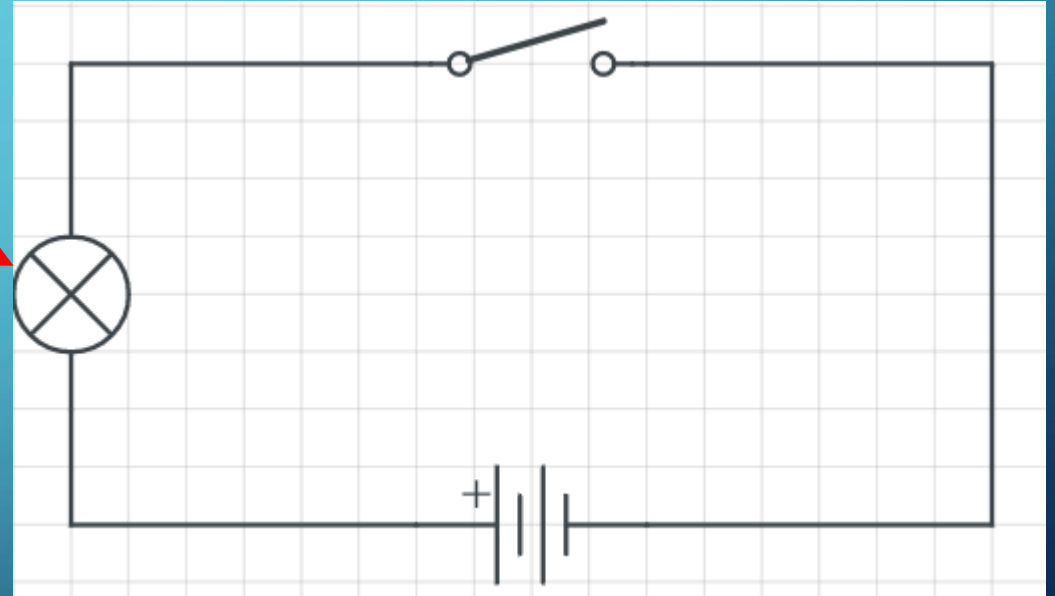

# EXAMPLE: FLASHLIGHT COMPONENTS

## Light Bulb

- A device that converts electrical energy into light.
- Nowadays, LED lamps because they are brighter. It also uses less electricity, has a longer lifespan and less heat generation.

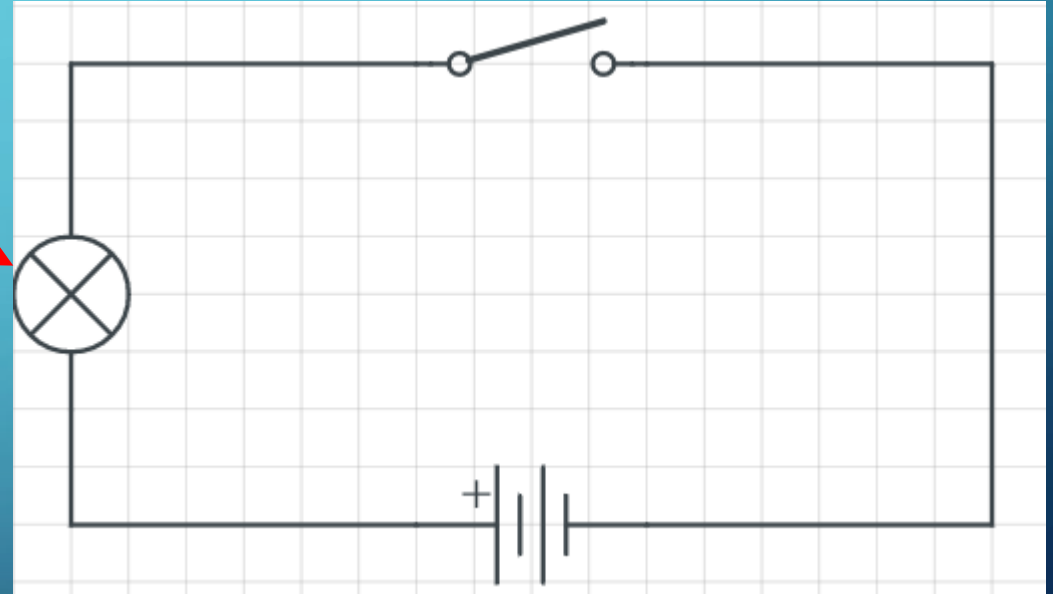

# EXAMPLE: FLASHLIGHT COMPONENTS

What is this?

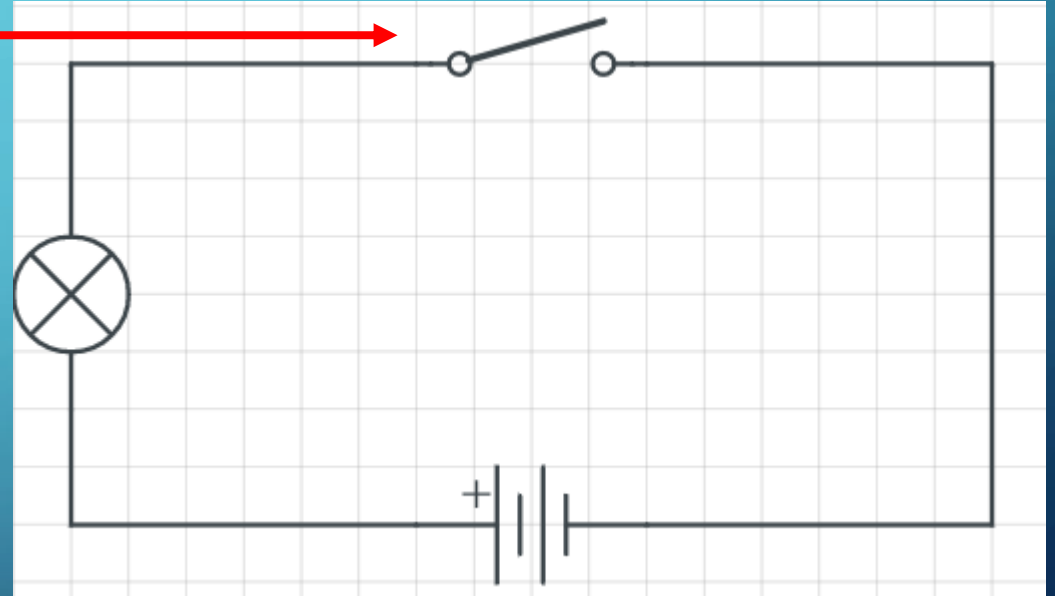

# EXAMPLE: FLASHLIGHT COMPONENTS

## Switch

- It is a device that acts as a circuit breaker.
- It controls the flow of electric current

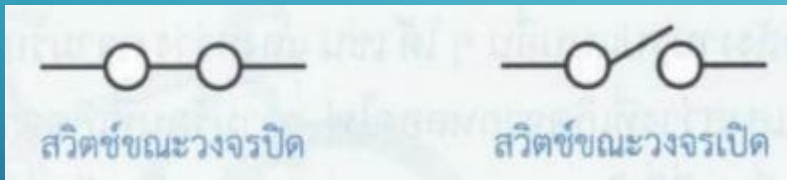

- There are many types of switches such as

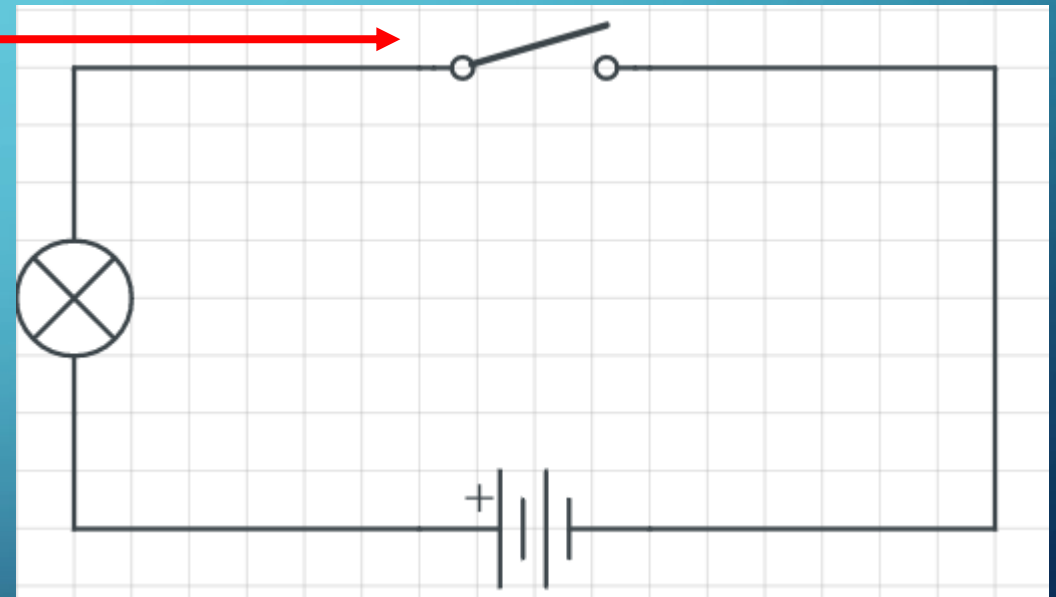

# EXAMPLE: FLASHLIGHT COMPONENTS

What is this?

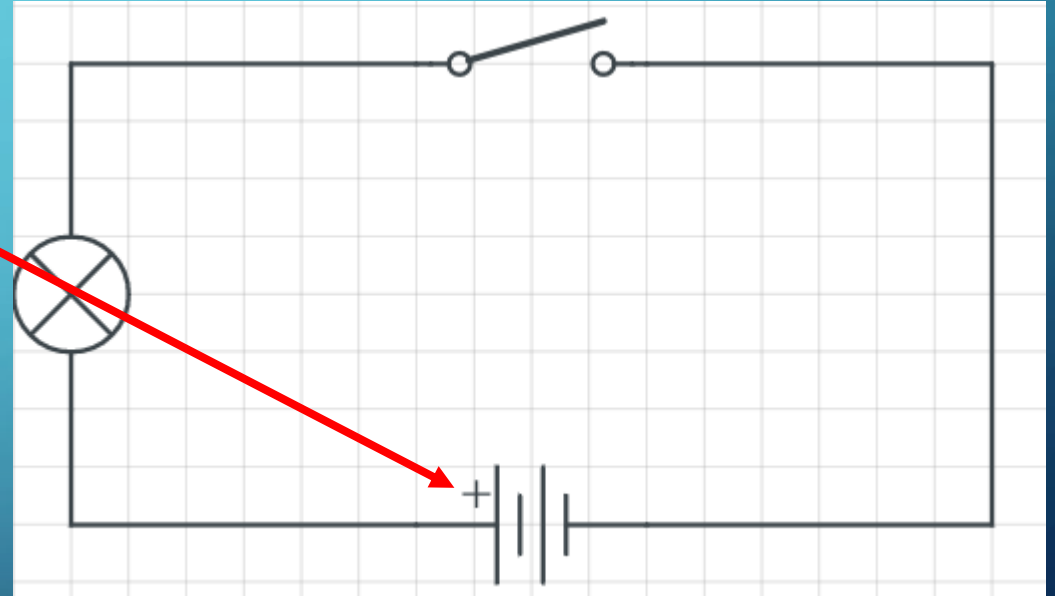

# EXAMPLE: FLASHLIGHT COMPONENTS

## Source

- It is a DC power source with breaking patterns such
- Usually batteries of AA, AAA type, typically rated for 1.5 Volts and 9 Volts

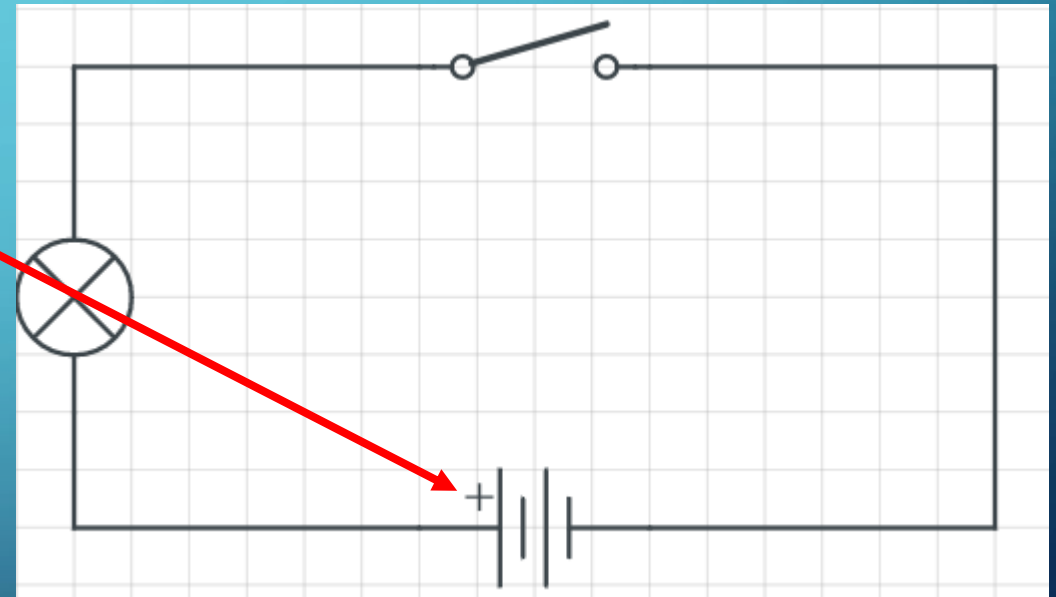

# EXAMPLE: FLASHLIGHT COMPONENTS

What are these lines?

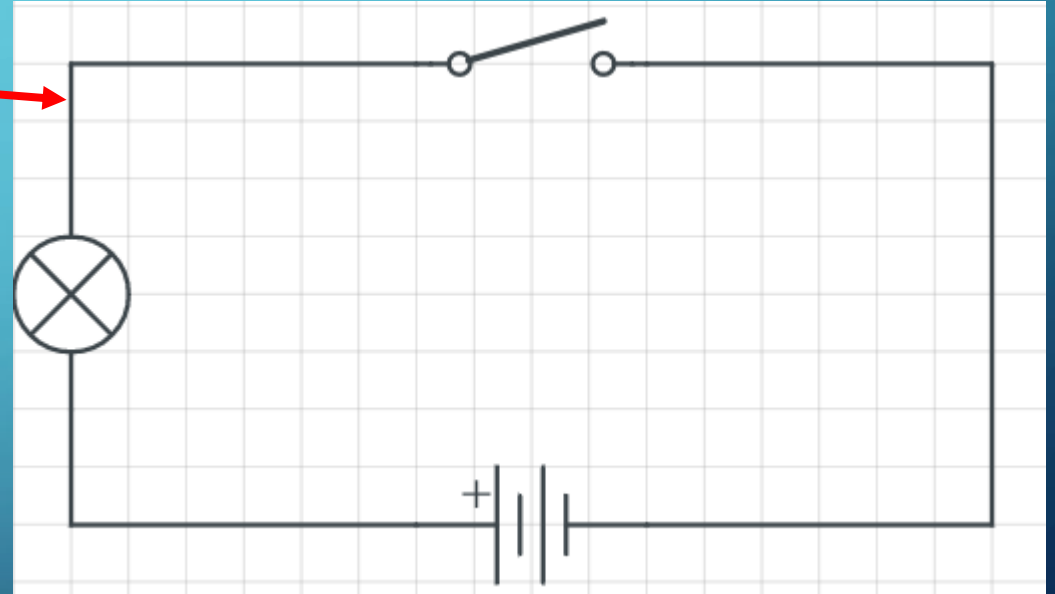

# EXAMPLE: FLASHLIGHT COMPONENTS

## Wires

- The wire or metal plate connected between the negative terminal of the battery and the switch connected to one of the lamp terminals
- To be a path of electricity from the battery to the terminals of the lamp.

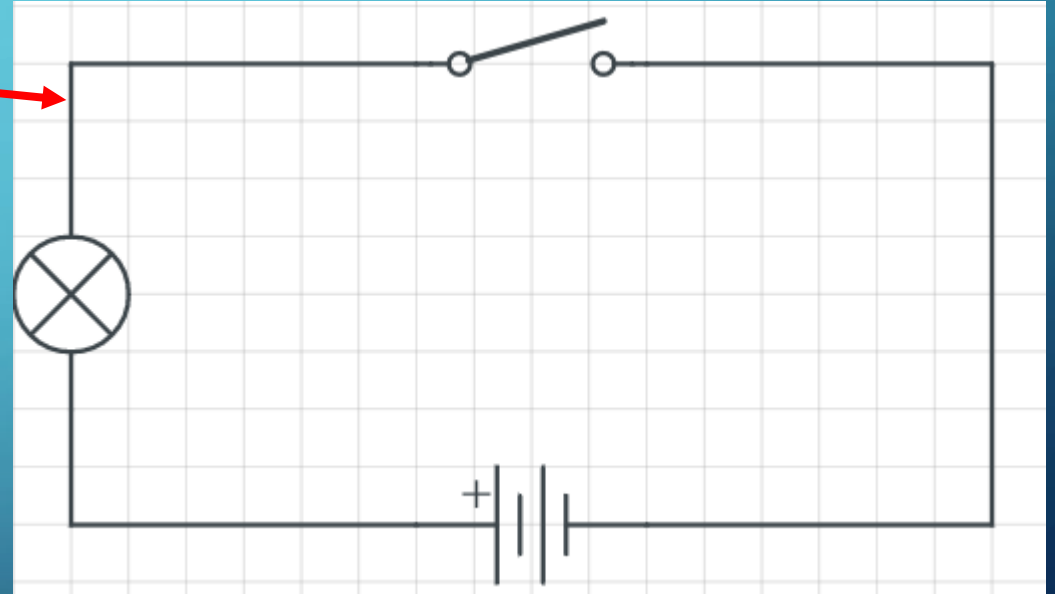

# ELECTRONIC COMPONENTS

- We have many different types of electric components that we use in our everyday life
- For example LED, diodes, resistors, capacitors, transistors, microcontrollers, transformers, fuses, relays, switches, circuit breakers, bell, motor...

# WHAT IS A DIODE?



# DIODES

- Diodes allow electric current to flow in a single direction only
- Each diode has two terminals known as the anode and cathode
- When the anode is charged with positive voltage and the cathode with a negative one, electric current can flow
- Reversing these voltages will prevent the current from flowing

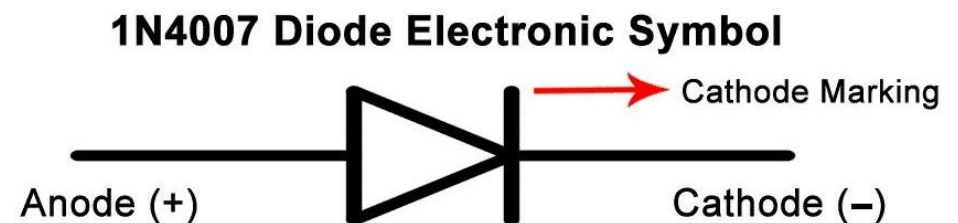

# DIODES

**Electricity can flow**

**Electricity can't flow**

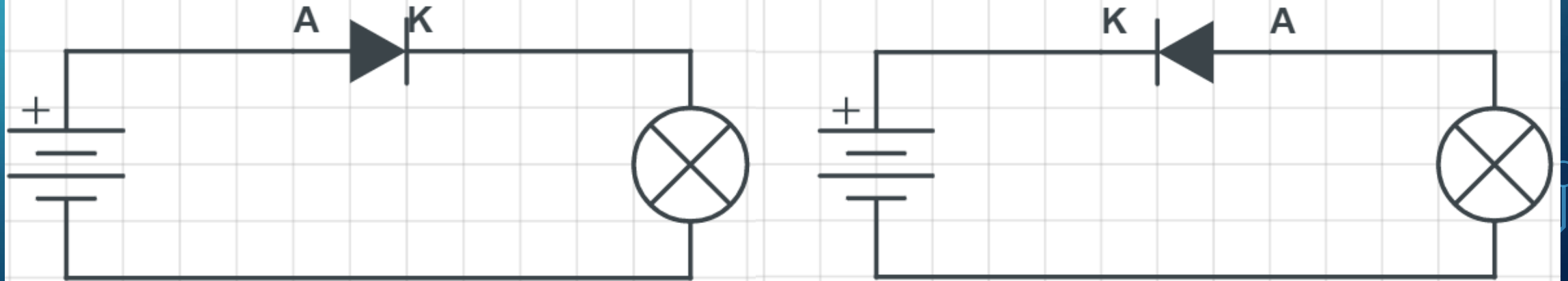

# WHAT IS AN LED?

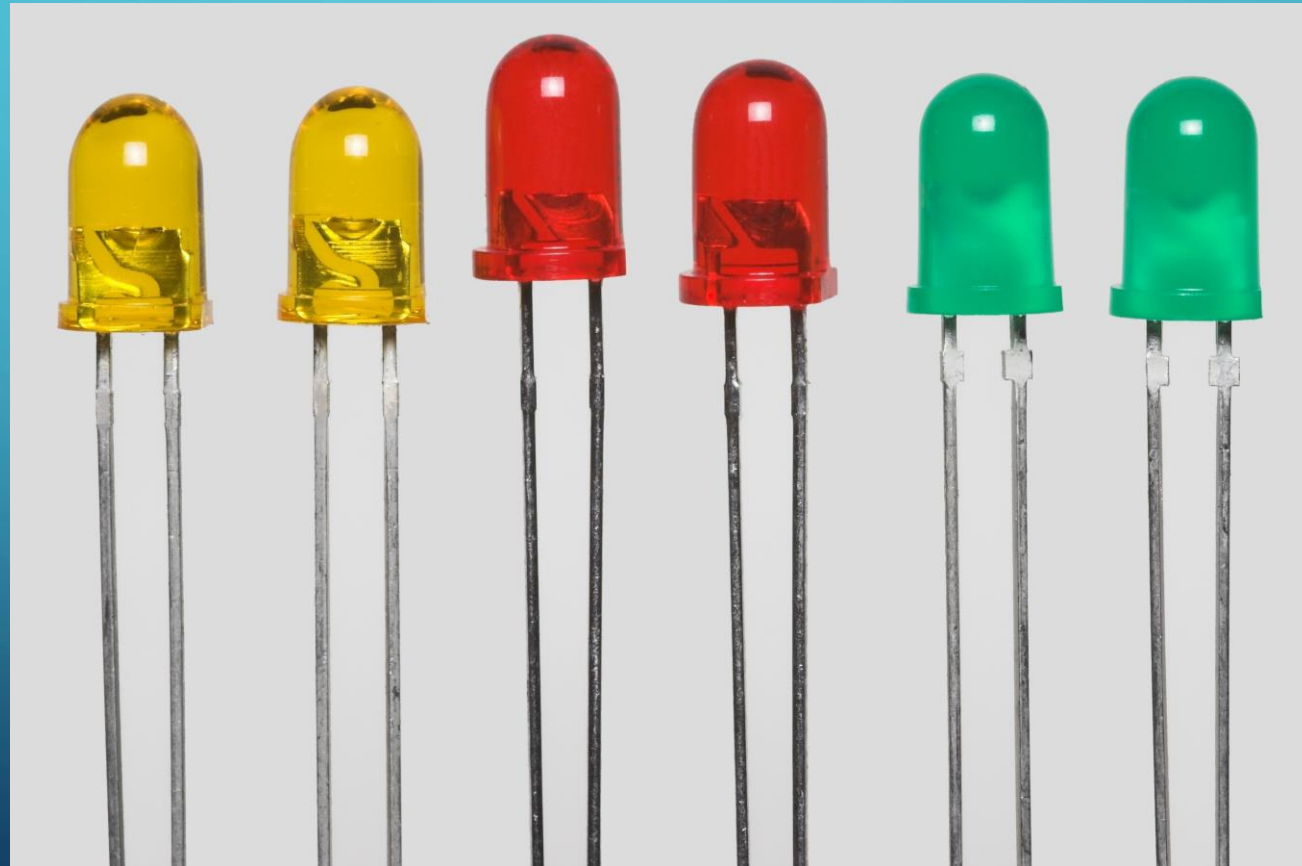

# LED

- Light Emitting Diode is a component that converts electrical energy into light
- It can be in many different colors
- It uses less energy and it is brighter than incandescent light bulbs

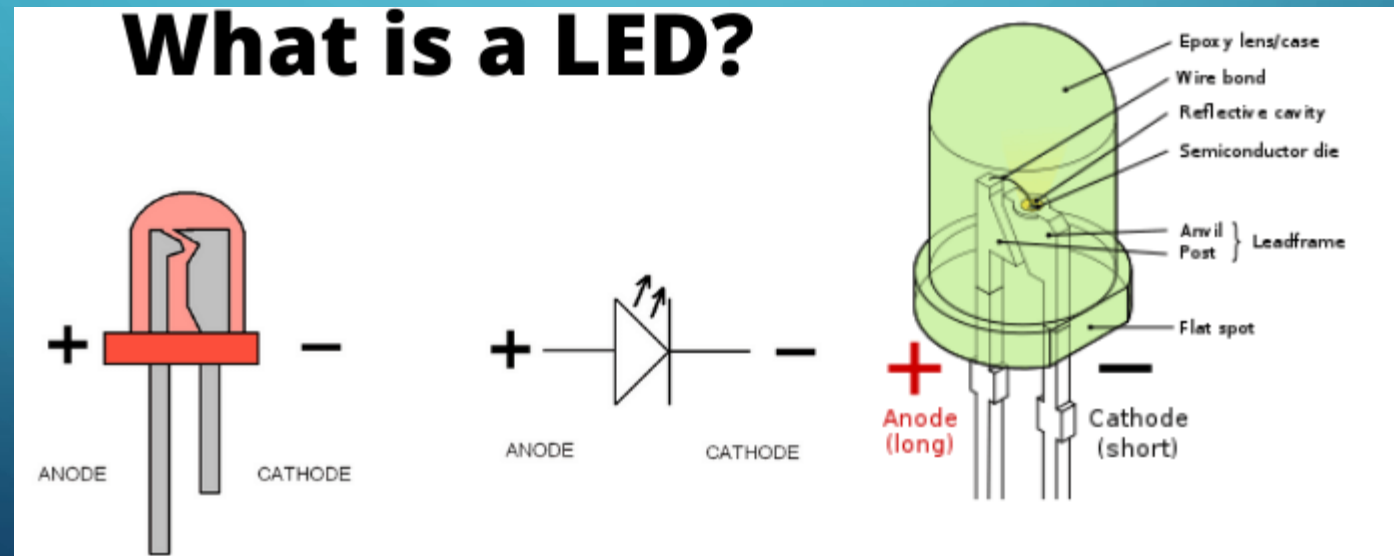

# WHAT IS A RESISTOR?

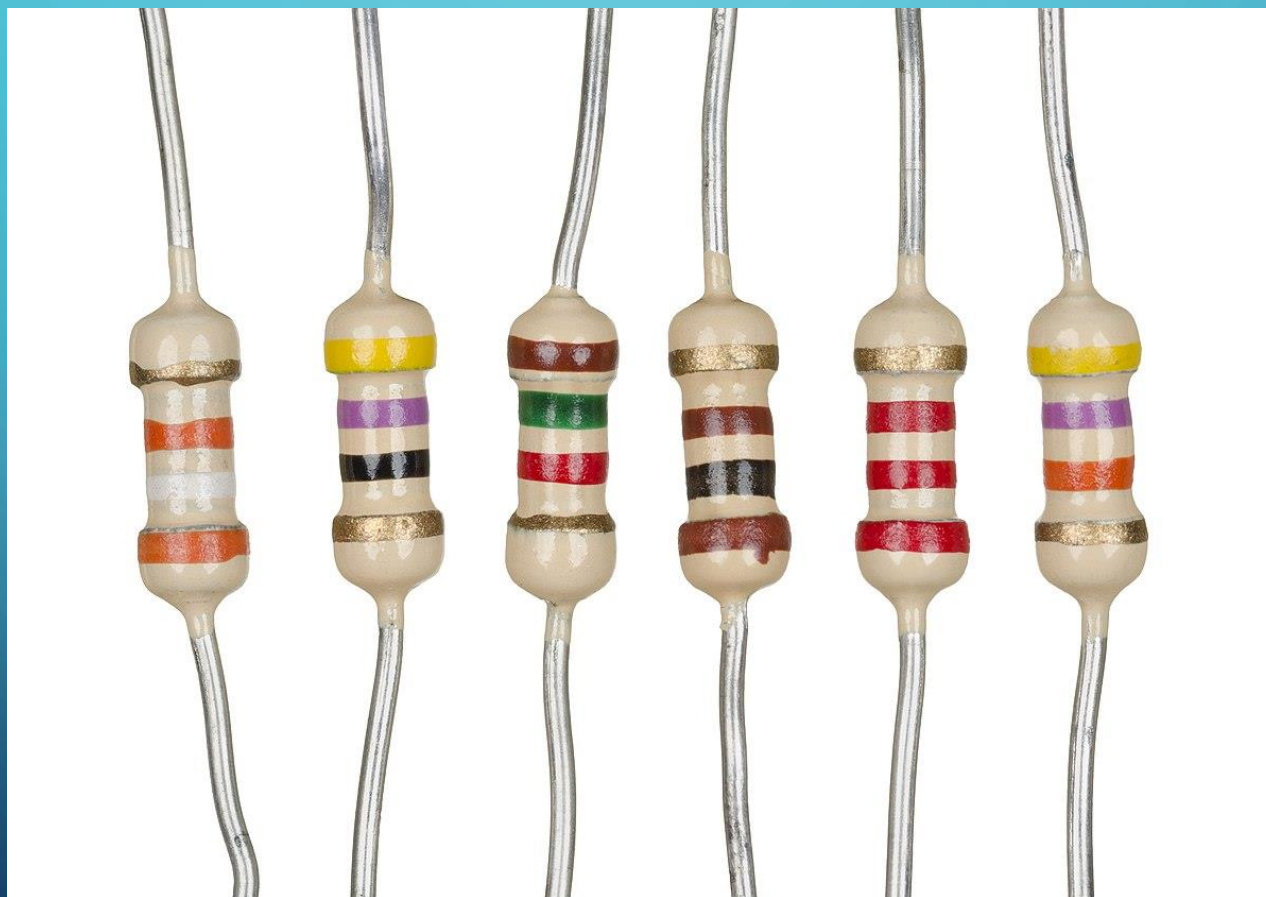

# RESISTOR

- Like the name suggests, the device resists the flow of current
- Resistors are graded based on their power ratings (amount of power they can handle without exploding) and resistance values (capacity to resist current)
- The measurement is done in units know as ohms  $\Omega$

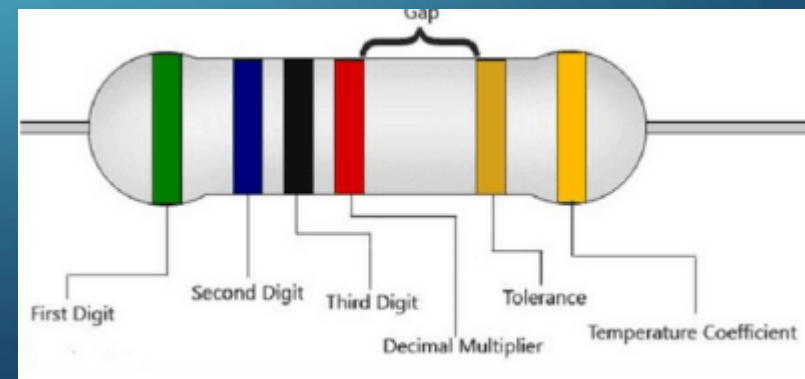
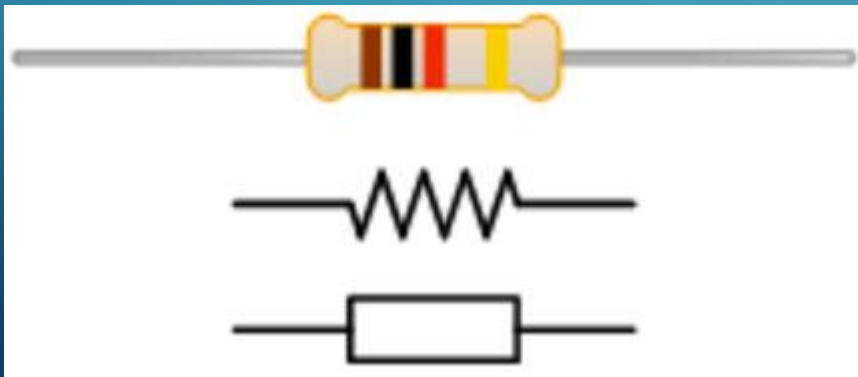

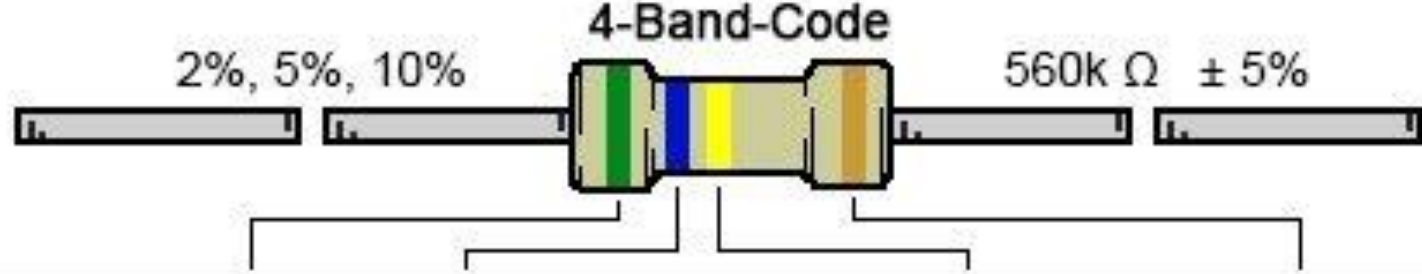

COLOR	1 <sup>ST</sup> BAND	2 <sup>ND</sup> BAND	3 <sup>RD</sup> BAND	MULTIPLIER	TOLERANCE
Black	0	0	0	1 $\Omega$	
Brown	1	1	1	10 $\Omega$	$\pm$ 1% (F)
Red	2	2	2	100 $\Omega$	$\pm$ 2% (G)
Orange	3	3	3	1K $\Omega$	
Yellow	4	4	4	10K $\Omega$	
Green	5	5	5	100K $\Omega$	$\pm$ 0.5% (D)
Blue	6	6	6	1M $\Omega$	$\pm$ 0.25% (C)
Violet	7	7	7	10M $\Omega$	$\pm$ 0.10% (B)
Grey	8	8	8	100M $\Omega$	$\pm$ 0.05%
White	9	9	9	1G $\Omega$	
Gold				0.1 $\Omega$	$\pm$ 5% (J)
Silver				0.01 $\Omega$	$\pm$ 10% (K)

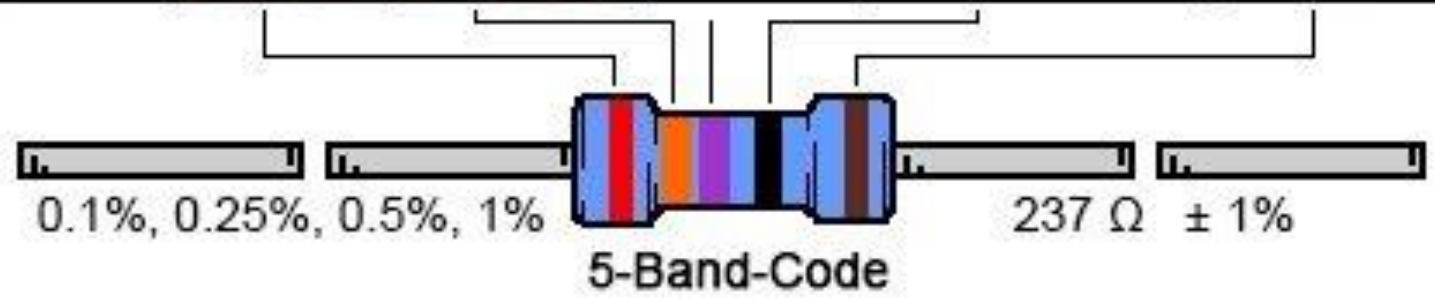

# WHAT ARE CAPACITORS?

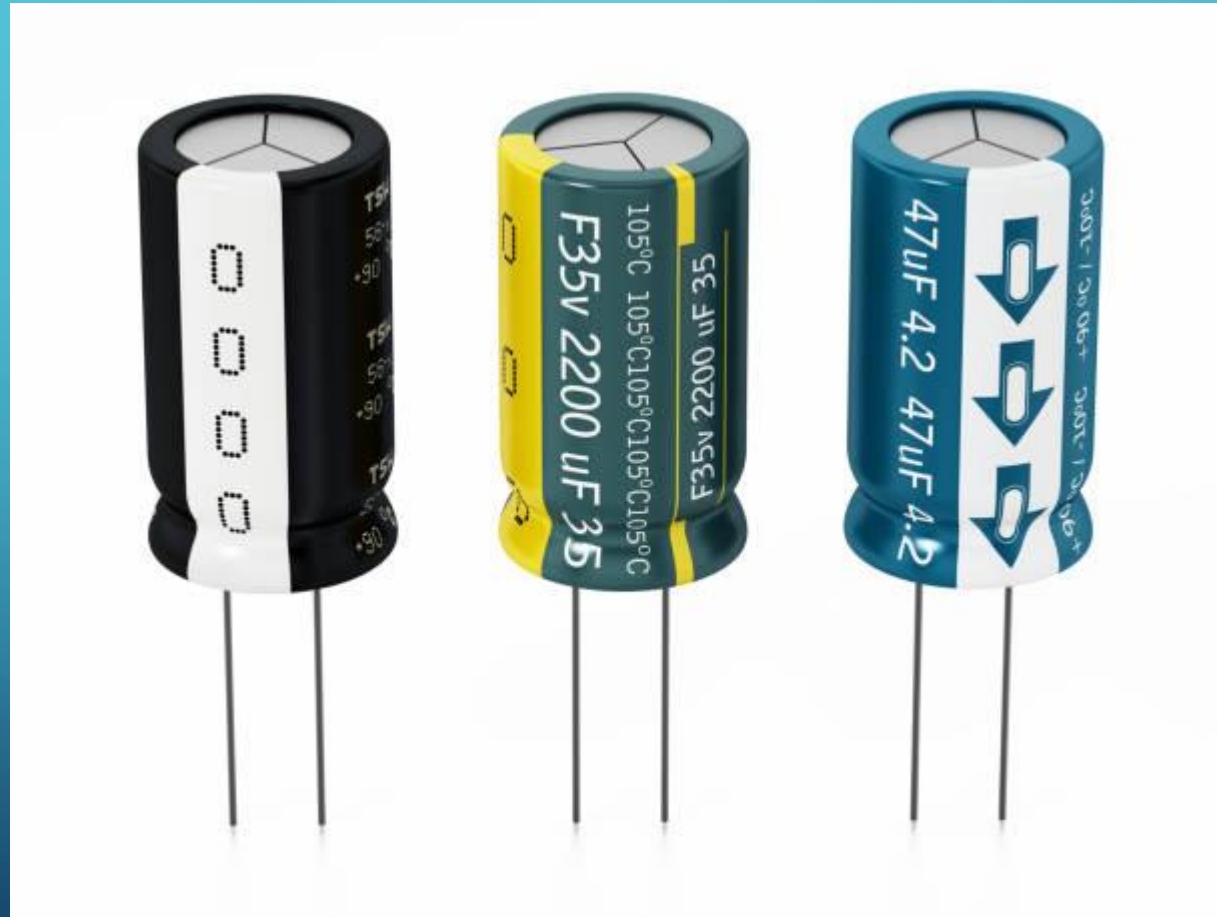

# CAPACITORS

- These components can store electric charge temporarily
- The components come in different varieties, with the most common ones being electrolytic and ceramic disk
- The capacity of a component is usually measured in microfarads  $\mu\text{F}$

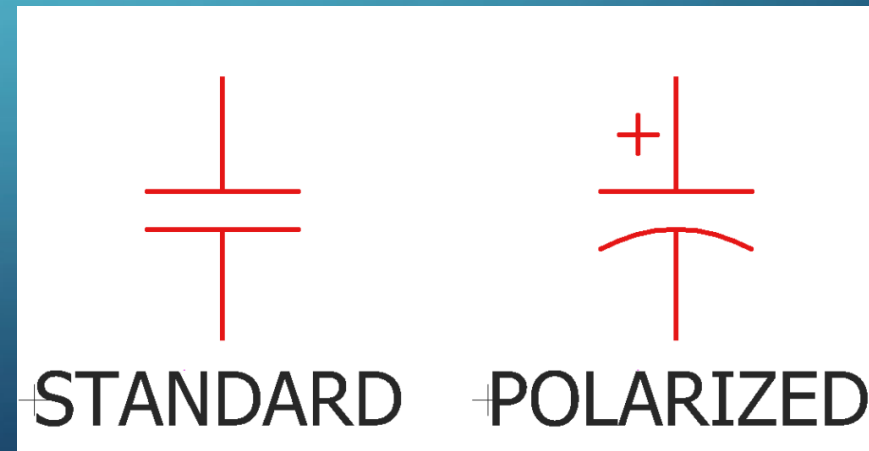

# Capacitor Types

Paper



Polystyrene

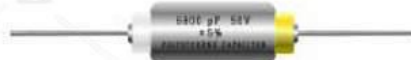

Bipolar



Electrolytic



Polycarbonate



Polyester



Mylar



Silver Mica



Ceramic



Tantalum Electrolyte



Feed Through



Trimmer



Variable



# WHAT ARE TRANSISTORS?

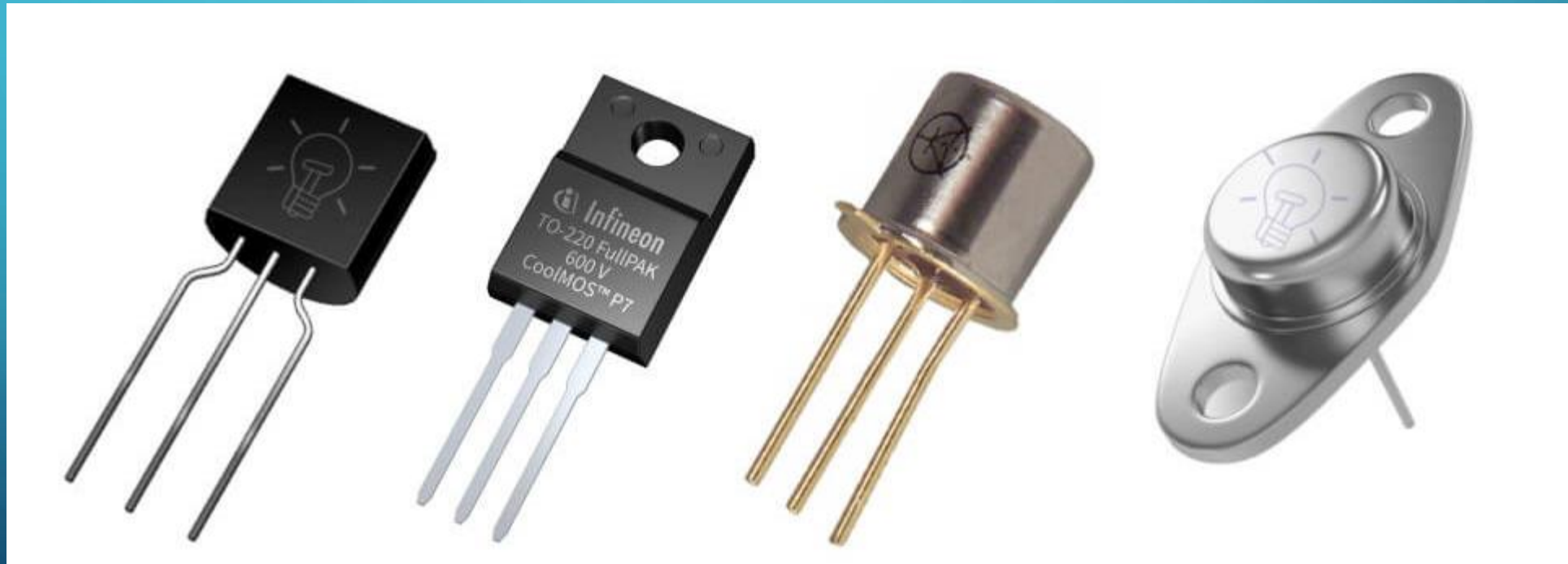

# TRANSISTORS

- These components are easy to identify through their three terminals
- For the components to work, voltage has to be applied to one of them; the base terminal
- The base can then control current flow in the two other terminals (the emitter and collector)

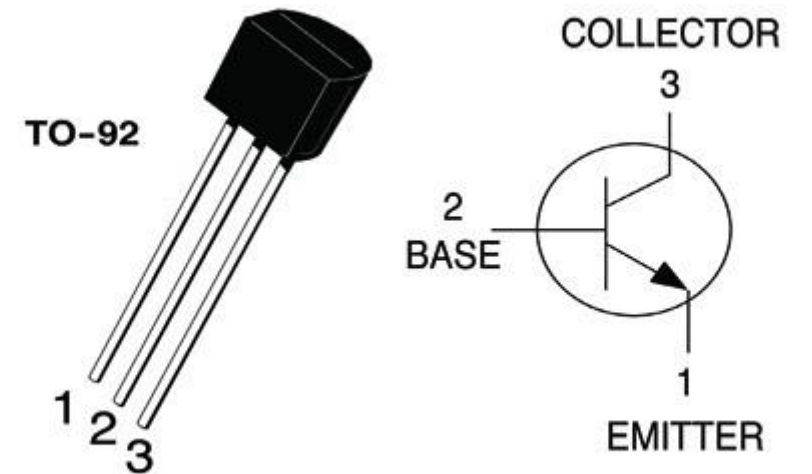

**2N3904 Pinout**

# WHAT ARE MICROCONTROLLERS?



# MICROCONTROLLERS

- Microcontrollers are small computers used to control a multitude of devices, such as power tools, remote controls, medical equipment and office machines

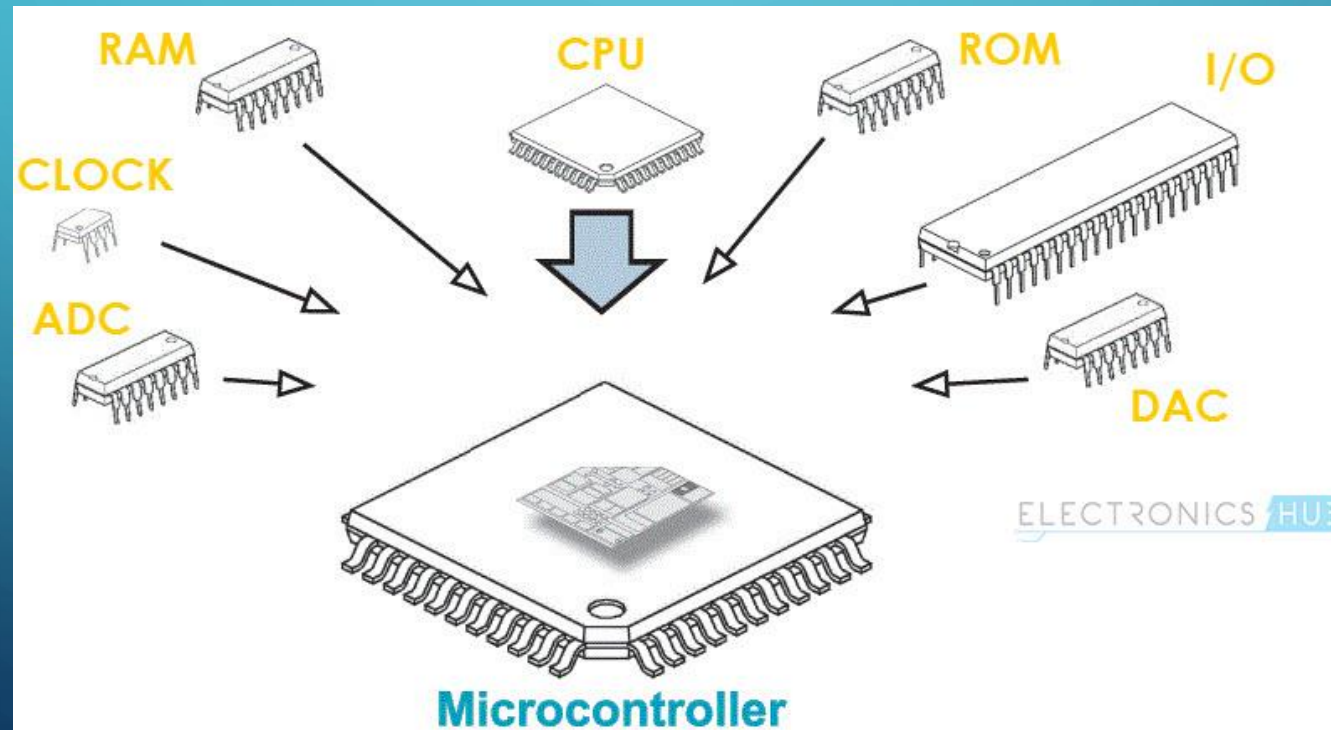

# WHAT ARE TRANSFORMERS?



# WHAT ARE TRANSFORMERS?



# TRANSFORMERS

- Built with two coils of wire, transformers are commonly used to step up or step down power

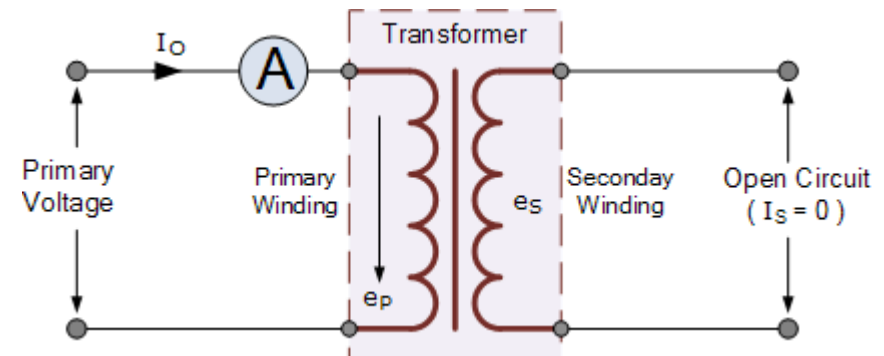
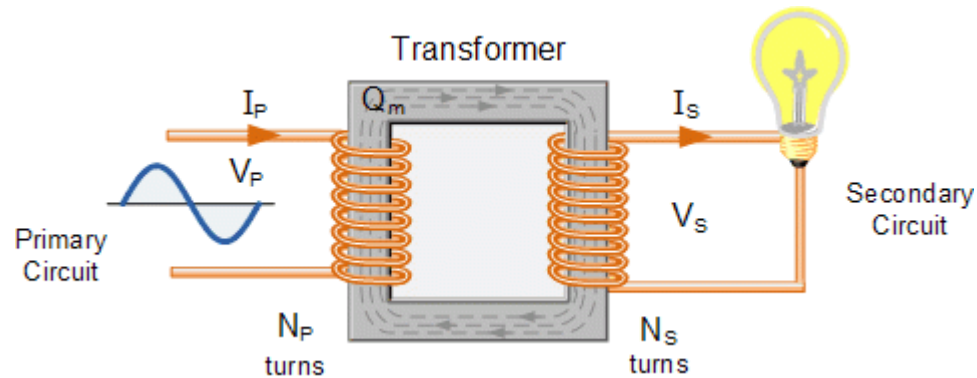

# WHAT ARE FUSES?



# FUSE



- Fuses help preserve components from overloading with excessive current
- A fuse consists of connection body, support, contacts, and metal-fuse material such as zinc or copper.



# WHAT ARE RELAYS?

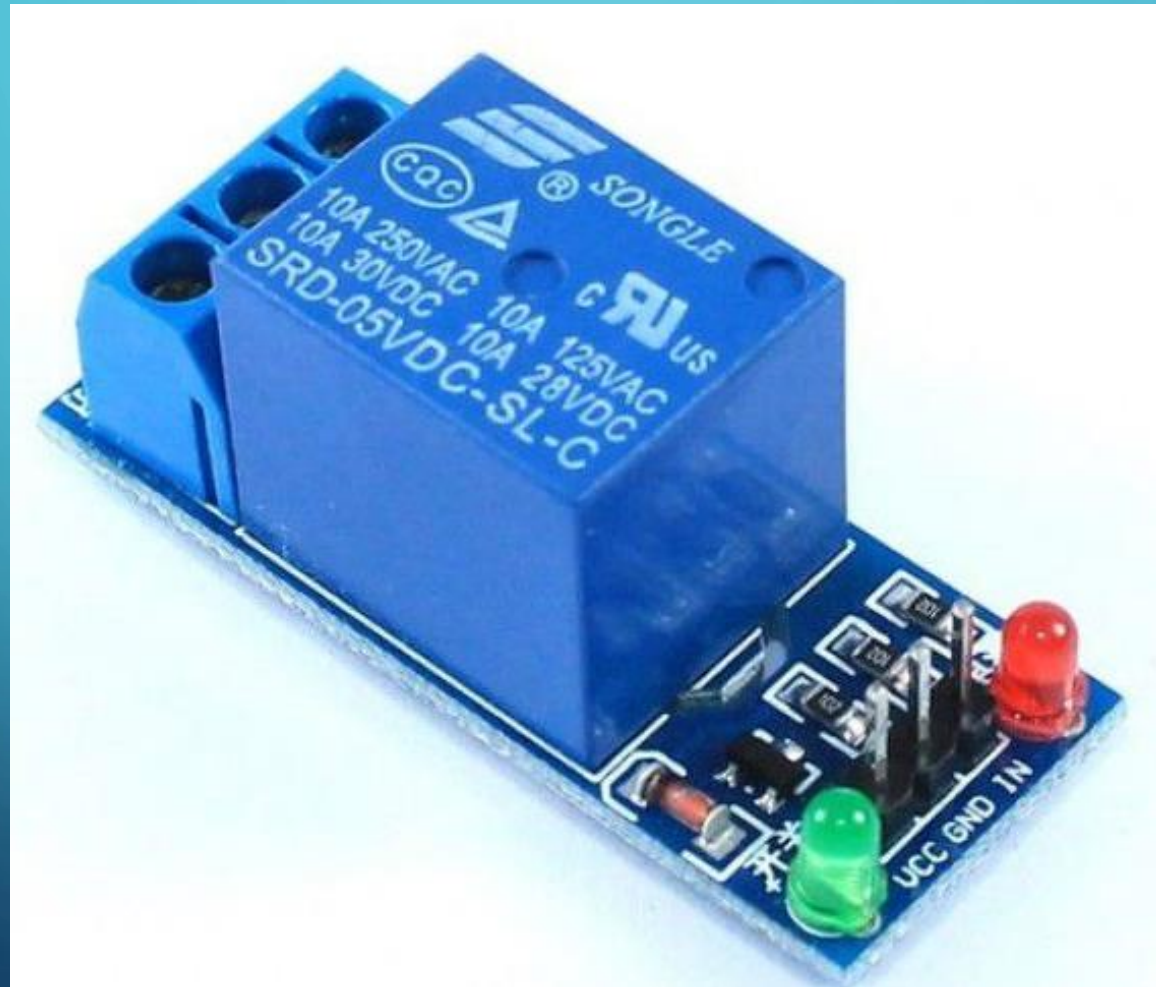

# RELAY

- These electromechanical switches shut power on or off
- A relay includes an electromagnet, an armature, a series of electrical contacts and a spring.

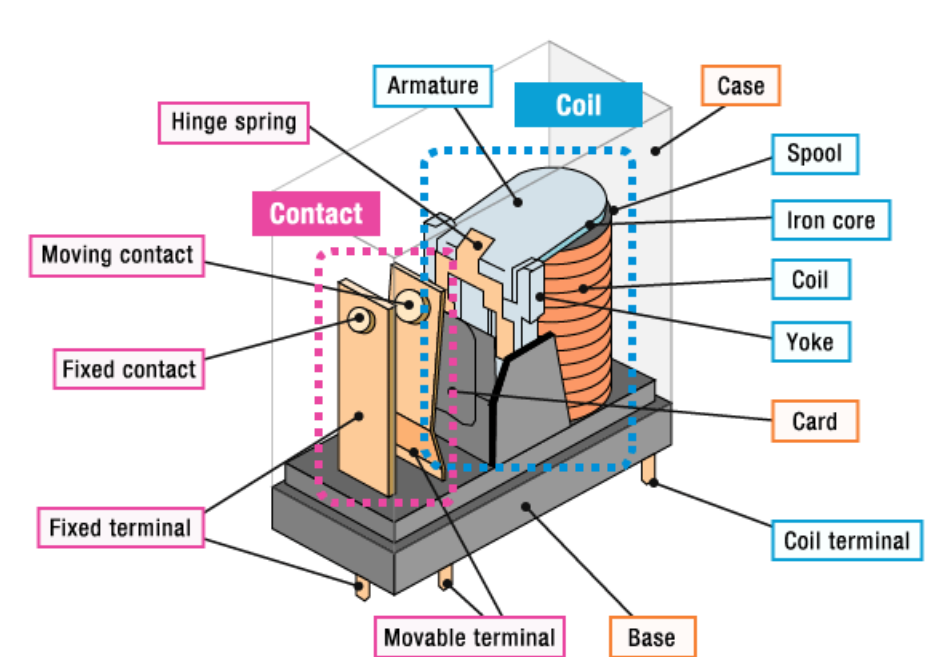
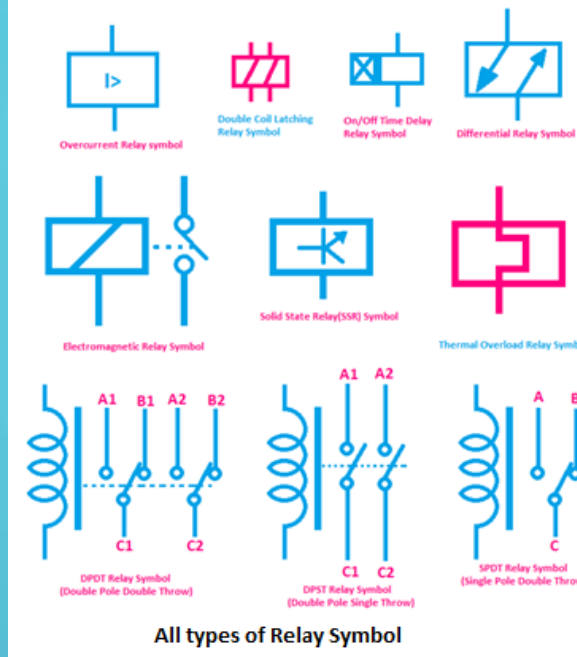

**Return state**  
**(8) The attracting force no longer exists**

The current stops flowing through the coil and the force to attract the armature no longer exists and the armature returns to its original position by the force of the release spring.

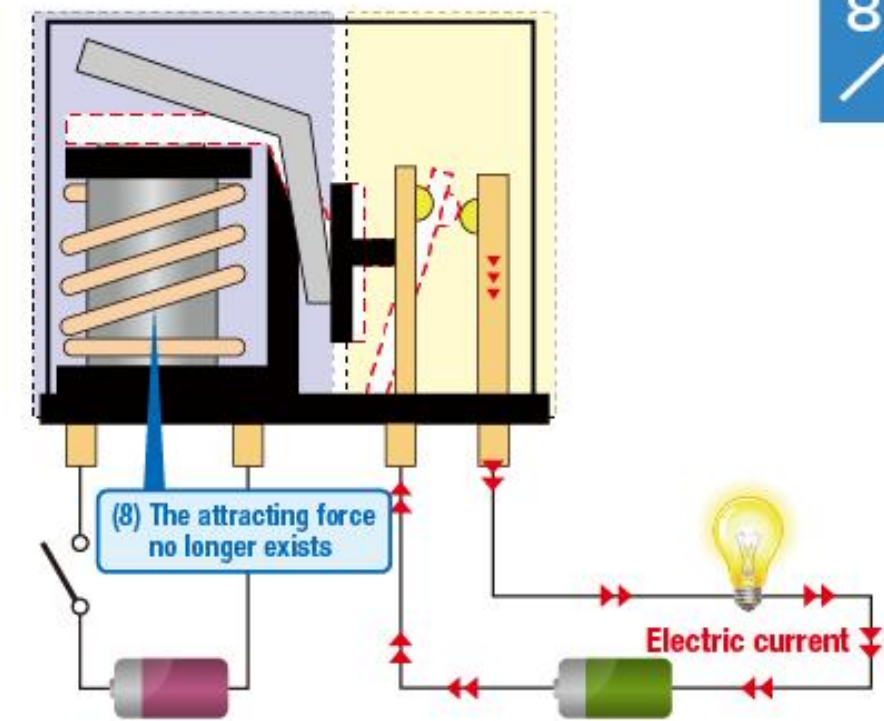

# WHAT ARE SWITCHES?



# SWITCH

- A Switch is a simple device that is used to break a circuit and disturb the flow of electrons.
- Most common types of mechanical switches are:

1. Toggle Switches
2. Push Button Switches
3. Rocker Switches
4. Rotary Switches
5. Slide Switches
6. Microswitches

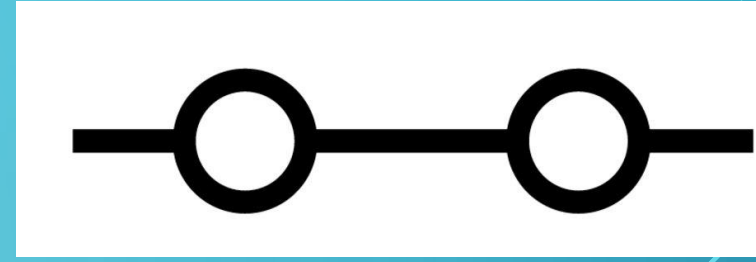
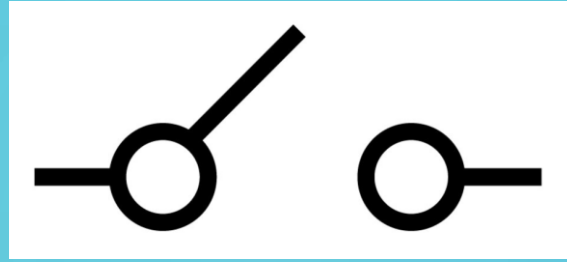

# SWITCH SYMBOLS

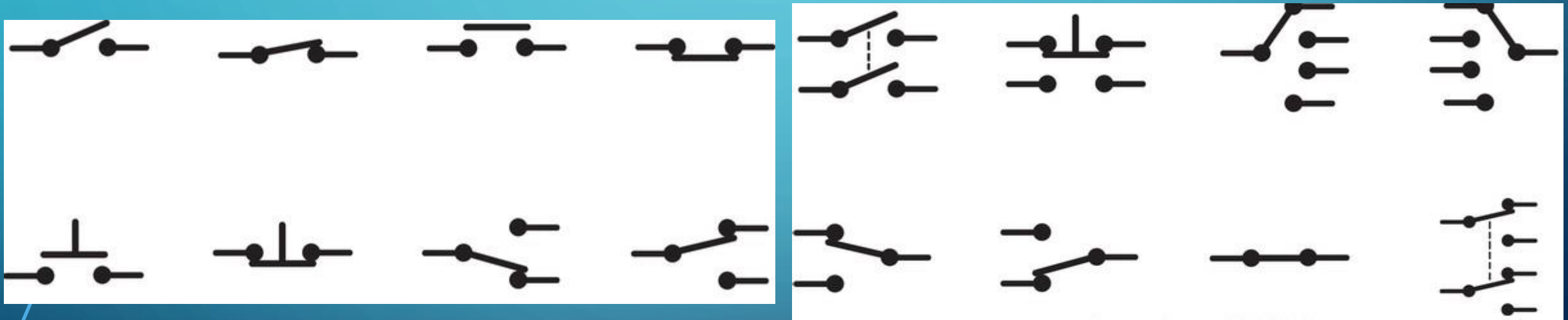

# WHAT ARE CIRCUIT BREAKERS?



# CIRCUIT BREAKER

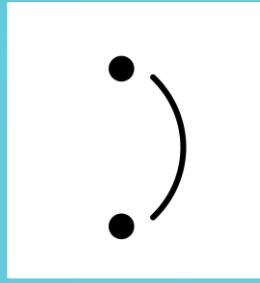

- As a protective device, a circuit breaker can be controlled with a remote switch
- It is designed to protect the circuit from overloading or a short circuit.

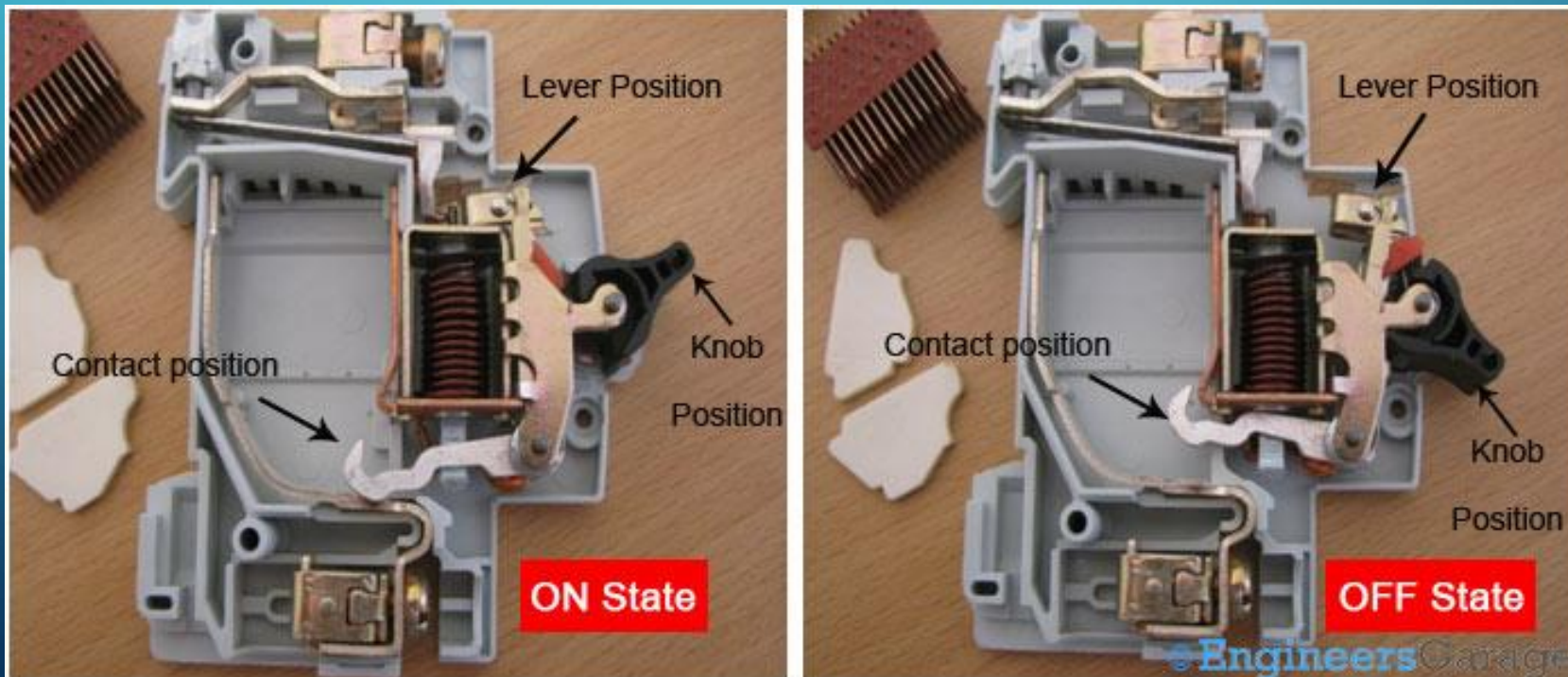

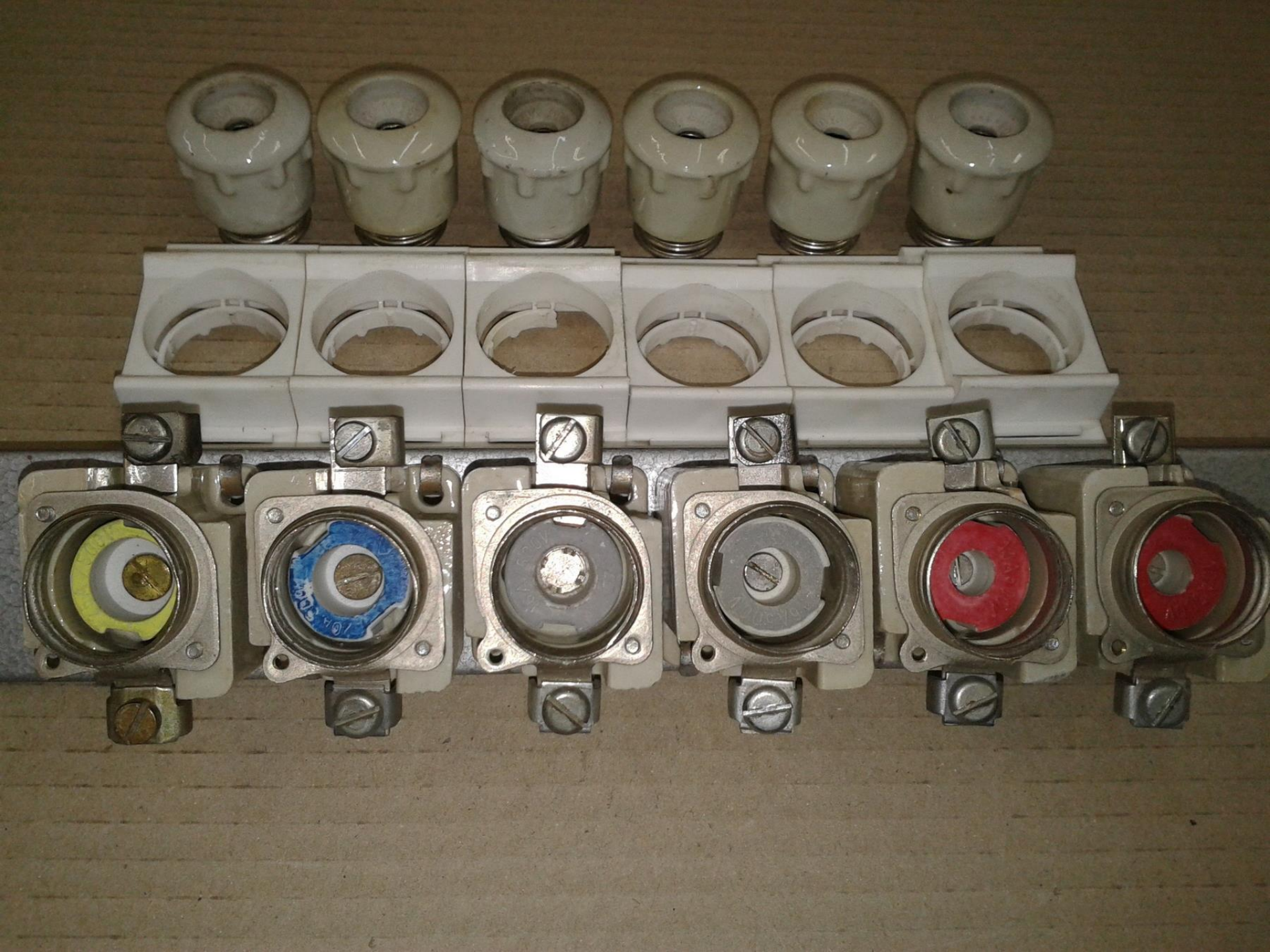



# WHAT ARE MOTORS?



# MOTOR

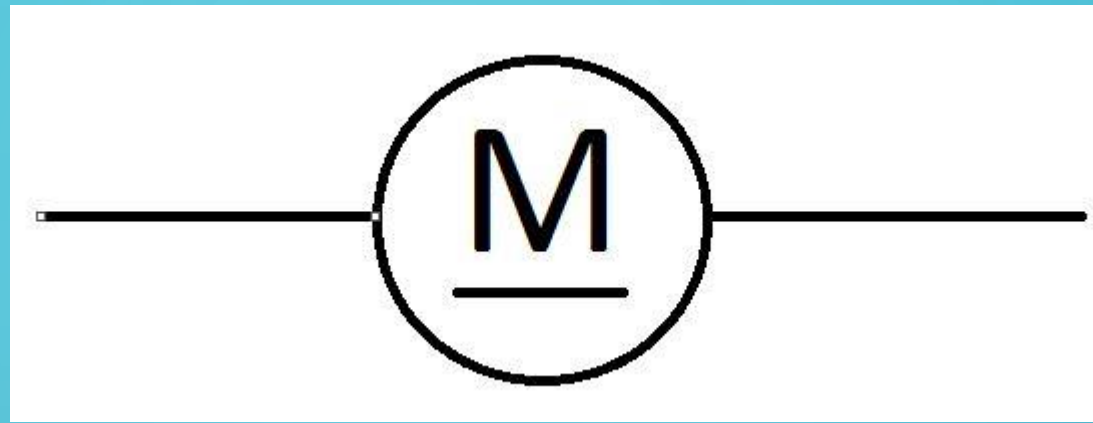

- Motors convert electrical energy into mechanical energy
- Key components include a rotor, stator, bearings, conduit box, enclosure, and eye bolt.

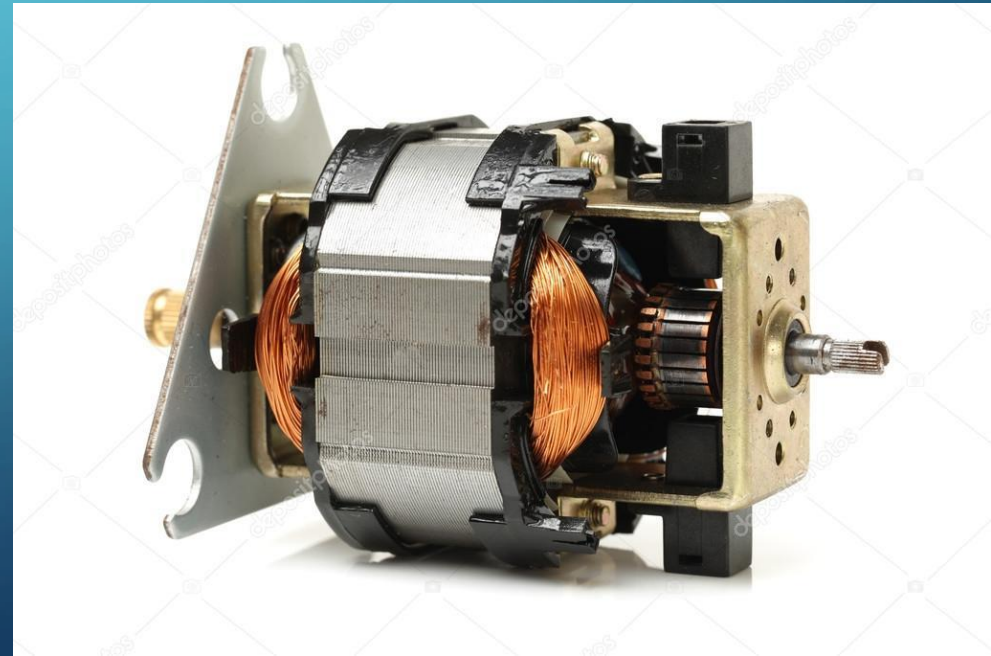

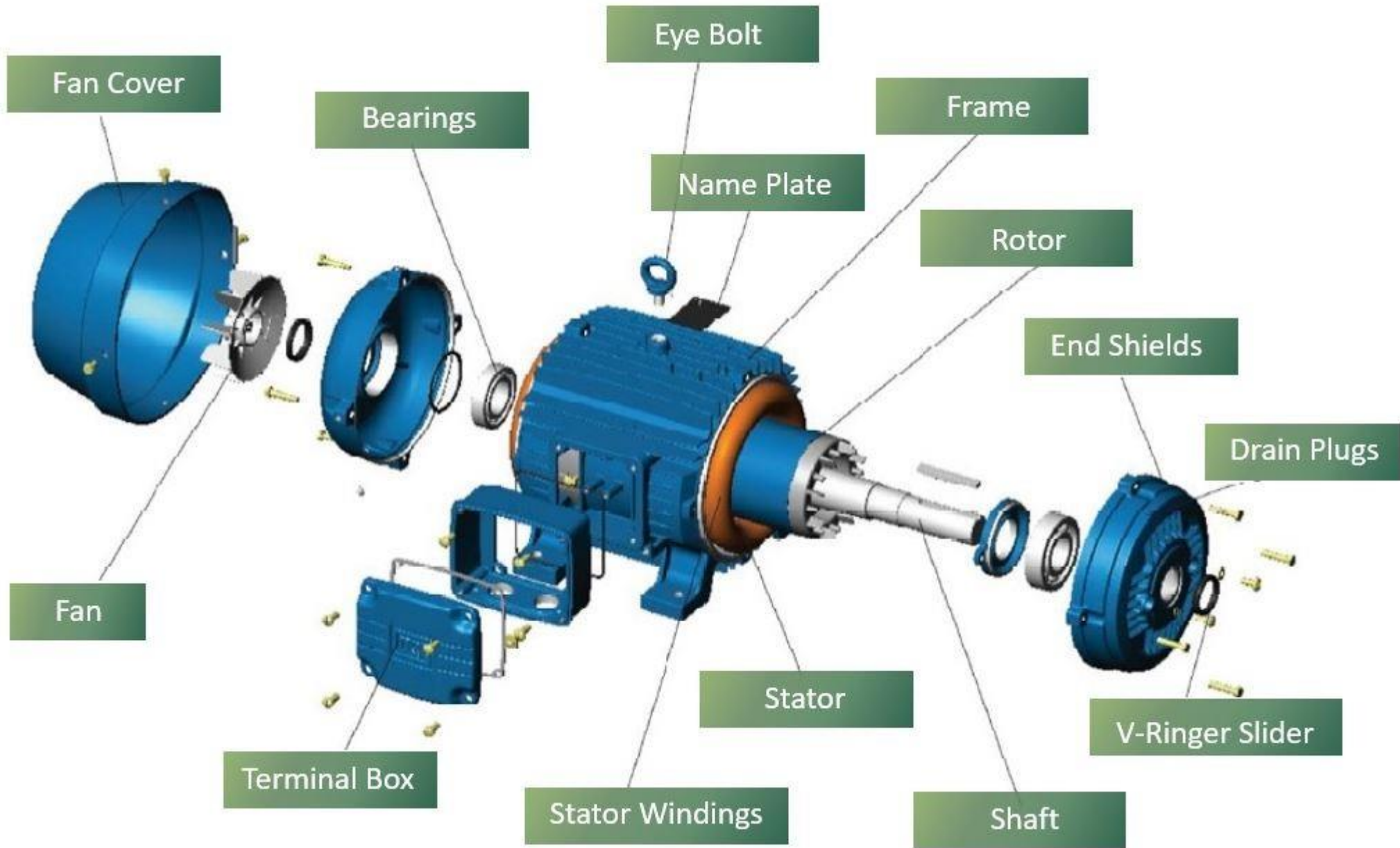



# WORKSHEET



ANY QUESTIONS?



THE END